

Article number: 81941811.BD

Bedrukking mogelijk

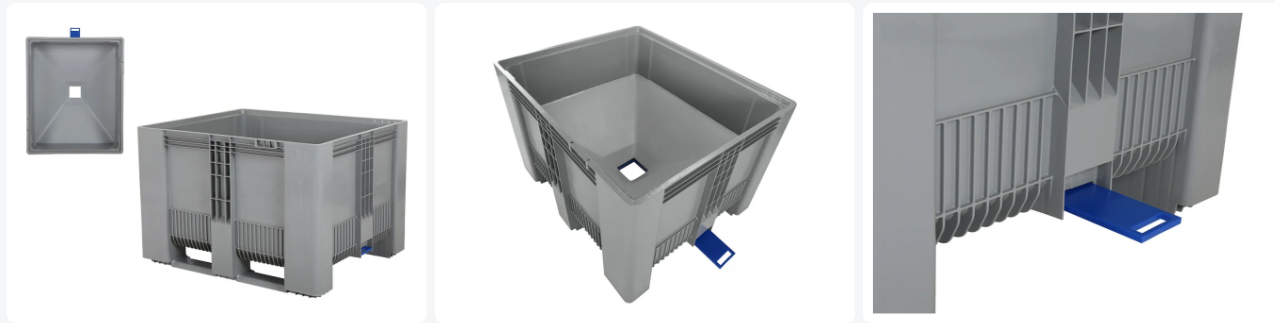

SB3 plastic palletbox - 1200 x 1000 mm - with funnel base and slide valve - on 2 runners



Product specifications

Uitwendig (LxBxH)	1200 x 1000 x 790 mm
Inwendig (LxBxH)	1110 x 910 x 590 mm
Capacity	500 liter
Sidewalls	Closed, reinforced
Material	HDPE
Article number	81941811.BD
Weight (kg)	55 kg
Temperature range	-30°C to +40°C
Color	Grey
Bottom	Closed, reinforced with central bottom discharge
Max. load capacity per box	700 kg
Max. static stacking load	5000 kg
Max. dynamic stacking load	1200 kg

Features

Type: SB3 pallet container

Function: funnel bottom

Dimensions: 1200 x 1000 x H 790 mm

Capacity: 500 liters

Material: standard plastic

Bottom outlet: centrally located in the base of the pallet box

Description

SB3 pallet container with funnel bottom (1200 x 1000 x H 790 mm - 500 liters). A standard plastic pallet box equipped with a bottom outlet located centrally in the base of the pallet box. In the lower part of the pallet box, a tapered hopper bottom is welded with a central opening of 120x120mm (adjustable). This opening is closed by a slide valve that can be manually operated from the short side. The SB3 box with its smooth, funnel-shaped interior is ideal for the controlled dosing of dry bulk goods such as granules, seeds, grains, dry animal feeds, pellets, and other small components. Thanks to the inclined bottom at an angle of 35°, the product flows easily outwards when the slide valve is opened, eliminating the need for tilting and pouring. The container is also suitable for use with food products. This pallet box cannot be used for liquids and moist products unless a plastic liner is used. Max. load capacity per box: 700 kg.



Geschikte accessoires



Alternatieve artikelen

